

Instructions

Combustible Gas Detector
Transmitter Model 505 with
Combustible Gas Sensor Model CGS



Table of Contents

SAFETY MESSAGES	i
-----------------------	---

Section I - Description and Operating Characteristics

DESCRIPTION	1
Sensor.....	1
GENERAL APPLICATION INFORMATION	1
SENSOR RESPONSE	2
FACTORS AFFECTING SENSOR SENSITIVITY	2
SPECIFICATIONS.....	4
Transmitter	4
Catalytic Sensor.....	5

Section II - Installation and Startup

INSTALLATION	6
Sensor Location.....	6
Wiring Requirements	7
Model 505 Wiring.....	7
Sensor Separation	7
Sensor Voltage Adjustment	8
Replacing an Existing K Series or Model 500 Transmitter . with a Model 505	10
STARTUP PROCEDURE	11
CALIBRATION	11
Calibration Procedure.....	11
Calibration using K-Factors	12

Section III - System Maintenance

TROUBLESHOOTING	13
ROUTINE MAINTENANCE	13
Checkout in Normal Mode.....	13
Sensor Inspection	13
Sensor Sensitivity	13
Sensor Replacement	14
REPLACEMENT PARTS.....	14
DEVICE REPAIR AND RETURN.....	14
ORDERING INFORMATION.....	15

Appendices

APPENDIX A - FM APPROVAL	16
APPENDIX B - CSA APPROVAL	17
APPENDIX C - ATEX / CE APPROVAL.....	18
APPENDIX D - IECEx APPROVAL	20

Safety Messages

IMPORTANT

Be sure to read and understand the entire instruction manual before installing, operating or servicing the gas detection equipment.



WARNING

Do not open the transmitter enclosure with power applied unless it is verified that no combustible gases or vapors are present. A portable gas detection instrument should be used to ensure that the area is clear of any combustible gases. Calibration or maintenance should not be performed if there is any indication of the presence of combustible gas at the sensor.



WARNING

It is possible for the transmitter output to drop to a low LFL level after going into high alarm and still have a dangerous level of combustible gas present. Therefore, precautions should be taken to ensure that the combustible gas has been cleared before considering the area safe.



WARNING

The sintered metal flame arrestor is an integral part of the combustible gas sensor. DO NOT operate the gas detector if the flame arrestor is damaged or missing, since the exposed element is a potential ignition source.

CAUTION

To ease installation and future removal, ensure that all junction box covers and sensor threads are properly lubricated. If the need arises for additional lubrication, use either Lubriplate grease (P/N 102868-001) or Teflon tape for sensor threads. Avoid the use of silicone grease.

CAUTION

The wiring instructions in this manual will provide safe and proper functioning of the device under normal conditions. However, local variations in wiring codes and regulations exist, and total compliance with these ordinances cannot be guaranteed. Be certain that all wiring complies with the IEC/NEC as well as all local ordinances. If in doubt, consult the local authority having jurisdiction before wiring the system.

NOTE

Throughout this manual, the device receiving the output signal from the transmitter will be referred to as the "controller." A typical controller provides a visual display of the % LFL output from the monitored transmitter, indicators for alarm and trouble conditions, and outputs for controlling response devices. Other control systems are also compatible with the Model 505.

Combustible Gas Detector
Transmitter Model 505 with
Combustible Gas Sensor Model CGS

SECTION I
DESCRIPTION AND
OPERATING
CHARACTERISTICS

DESCRIPTION

The Model 505 Transmitter is used with one constant voltage catalytic gas sensor to provide a linear 4 to 20 mA output signal corresponding to a 0 to 100% LFL gas concentration (see Figure 1). Intrusive calibration and sensor sensitivity checks are performed using a standard digital voltmeter (not provided). An explosion-proof junction box with removable cover is included with all Model 505 Transmitters. Options include junction box material (aluminum or stainless steel), number of conduit entry ports (up to five), conduit entry threads (NPT or Metric), orientation of entries (180 degree straight-through or 90 degree "L"), and signal output load impedance (125 or 500 ohms). Detector Electronics Corporation's (Det-tronics®) Model 505 with signal loop impedance option "A" directly replaces the K-Series Transmitter (125 ohms), and the Model 505 with signal loop impedance option "B" replaces the Model 500 Transmitter (500 ohms).

SENSOR

Det-Tronics constant voltage catalytic bead type combustible gas sensors are used with the Model 505 transmitter family.

GENERAL APPLICATION
INFORMATION

A combustible vapor or gas is one that will burn when mixed with air (or oxygen) and ignited. Every vapor has a minimum and maximum concentration in air, which together form the "flammable" or "explosive" range. The lower flammable limit (LFL) is defined as the smallest amount of the gas that will support a self-propagating flame when mixed with air (or oxygen) and ignited. The range



of gas concentration measurement for most catalytic sensor-based gas detection systems, including the Model 505 transmitter, is 0 to 100% LFL, with 0% LFL being a gas-free atmosphere and 100% LFL equaling the gas concentration at its lower flammable limit. The relationship between % LFL and % by volume differs from gas to gas. ASTM E681 is the existing standard method for determining flammable limits.

Examples include:

- Hydrogen (H₂), 100% LFL = 4.0% by volume in air
- Methane (CH₄), 100% LFL = 5.0% by volume in air
- Ethane (C₂H₆), 100% LFL = 3.0% by volume in air
- Ethylene (C₂H₄), 100% LFL = 2.7% by volume in air
- Pentane (C₅H₁₂), 100% LFL = 1.5% by volume in air
- Propane (C₃H₈), 100% LFL = 2.2% by volume in air

For data on other gases, refer to NFPA Handbook 325M.

Typical alarm setpoints for combustible gas detection systems are 20% LFL for the low alarm and 40% LFL for the high alarm.

The LFL of a gas is affected by temperature and pressure. As the temperature increases, the LFL concentration decreases, and the explosion hazard increases. The relationship between LFL and pressure is fairly complex, however, a

pressure increase usually lowers the LFL. The LFL of a gas is not significantly affected by the humidity fluctuations normally encountered in typical industrial applications.

SENSOR RESPONSE

Figure 2 shows the typical response of a catalytic gas sensor to various levels of methane. Note that a reading of 40% LFL will be given at 2.0% by volume methane and also at 80.0% by volume methane, which is well above the upper flammable limit. Although gas concentrations above the upper flammable limit will not propagate a flame, it is likely that somewhere in the protected area there may be a flammable concentration.

All catalytic sensors require oxygen to accurately measure combustible gas concentrations. Sensor response and accuracy will decrease when the oxygen level is less than 10%. Figure 3 shows the effect of oxygen enriched and oxygen deficient atmospheres on the response of a typical catalytic gas sensor. Do not use catalytic gas sensors in areas where the oxygen level is less than 10% by volume.

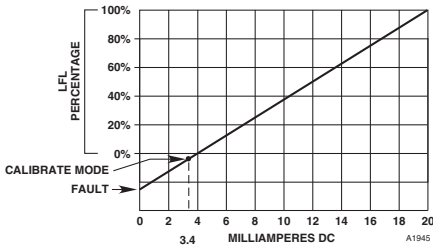

Figure 1—Transmitter DC Current Output

FACTORS AFFECTING SENSOR SENSITIVITY

There are a variety of factors that can cause a decrease in the sensitivity of catalytic type combustible gas sensors. The following information identifies the most common substances that can have a detrimental effect on the catalytic gas sensor. Under no circumstances should these lists be considered as all inclusive.

Interfering or contaminating substances include materials that can clog the pores of the sintered steel flame arrestor and reduce the gas diffusion rate to the sensor. Examples include:

1. Dirt or oil.
A dust cover or splash guard should be installed to protect the flame arrestor. The dust cover may be cleaned using an organic solvent and an ultrasonic bath unless the contaminant is insoluble. Replace dust cover if there is any doubt.
2. Corrosive liquids and vapors.
This can occur when substances such as H₂S, (hydrogen sulfide), Cl₂ (chlorine) or HCl (hydrochloric acid) are present. A dust cover may provide some limited protection. Routine calibration frequency should be increased in applications where corrosive materials are present.
3. Flame arrestor clogged as a result of painting or cleaning.
The routine maintenance procedure should include first powering down the system, then covering the sensor with a plastic bag when painting or cleaning. The bag should be removed as soon as possible when the procedure is complete. Recalibrate the sensors after re-powering and stabilization.
4. Polymer formation in the flame arrestor.
This can occur where monomeric vapors such as 1-3 butadiene, styrene, isoprene, etc. are present. This may render the sensor dead.

Some substances can cover or tie up the active sites on the catalytic surface of the active sensing element. This occurs in the presence of volatile metal organics, gases, hydride vapors, and volatile compounds containing phosphorous, boron, silicon, etc.

- Examples:
- Tetraethyl lead
 - Phosphine
 - Diborane
 - Silane
 - Trimethyl chlorosilane
 - Hydrogen fluoride
 - Boron trifluoride
 - Phosphate esters
 - Silicone oils and greases
 - RTV silicone sealants

Some substances react with the catalytic element metal, forming a volatile compound. This erodes the metal from the surface. With sufficient exposure, most or all of the metal catalyst can be removed from the surface of the active element

of the sensor. Halogens and compounds that contain halogens are materials of this nature.

- Examples:
- Chlorine
 - Bromine
 - Iodine
 - Hydrogen Chloride, Bromide or Iodide
 - Organic halides
 - Trichloroethylene
 - Dichlorobenzene
 - Vinyl chloride
 - Freons
 - Halon 1301 (Bromotrifluoromethane)

A brief exposure to any of these materials may temporarily increase the sensitivity of the sensor due to etching of the catalytic surface.

This practice is not recommended, since it is unreliable and may give a false sense of security.

Exposure to high concentrations of gas for extended periods can introduce stress to the sensing element and seriously affect its performance. After exposure to a high concentration of combustible gas, re-calibration should be performed and, if necessary, the sensor should be replaced.

The degree of damage to a catalytic sensor is determined by the type of contaminant, its concentration in the atmosphere, and the length of time the sensor is exposed. When a sensor has been exposed to a contaminant or to a high level of combustible gas, it should be re-calibrated at the time, followed by an additional calibration a few days later to determine whether a significant shift in sensitivity has occurred.

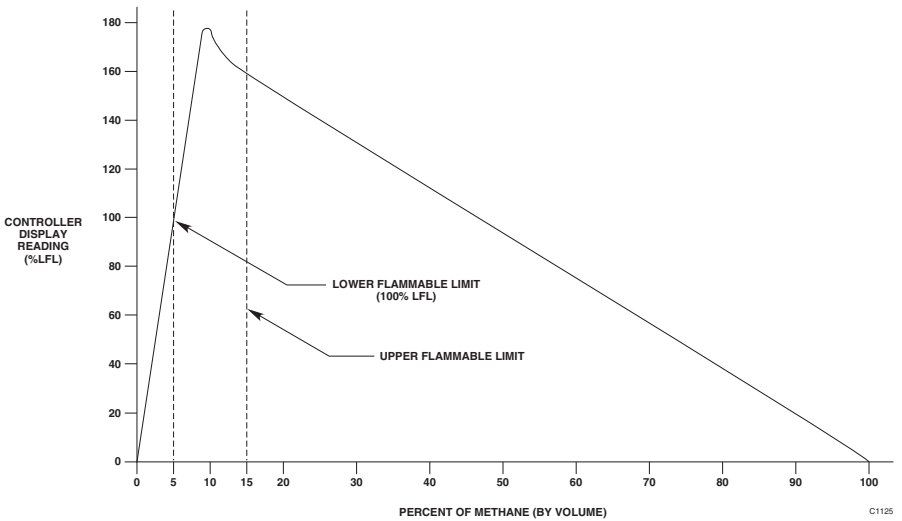

Figure 2—Typical Response of a Catalytic Sensor over a Range of 0 to 100% Methane by Volume

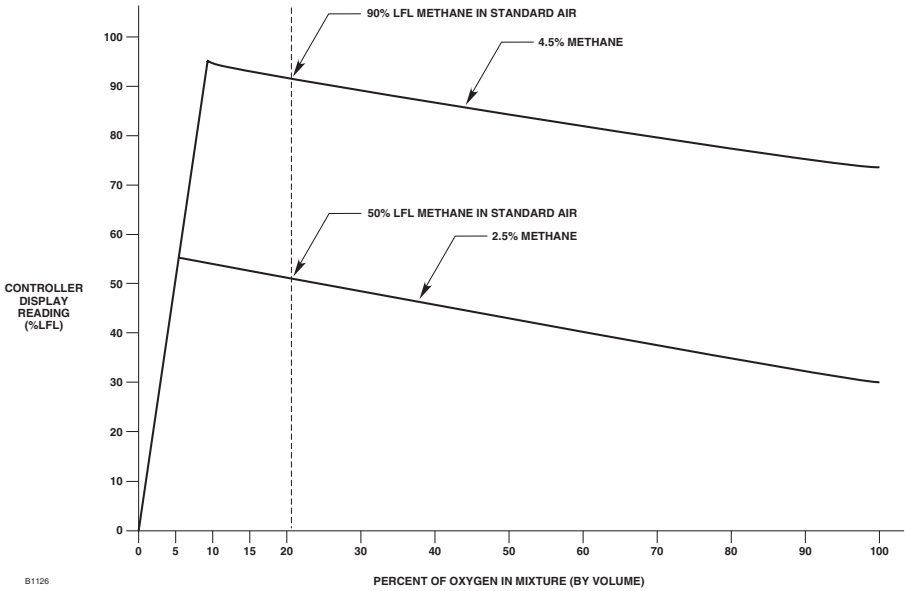

Figure 3—Effect of Oxygen Enriched and Deficient Atmospheres

SPECIFICATIONS

TRANSMITTER

INPUT VOLTAGE—

With signal loop impedance option A: 10 to 30 Vdc

With signal loop impedance option B: 17 to 30 Vdc.

Refer to “Description” section for additional information regarding impedance option.

Linear, regulated, filtered 24 Vdc power source is recommended.

POWER CONSUMPTION—

4.0 watts maximum.

PEAK STARTUP CURRENT—

Less than 0.5 ampere for < 0.2 second at 10 Vdc input, and less than 0.2 ampere for < 0.2 second at 24 Vdc input.

OUTPUT CURRENT—

Linear 4 to 20 milliamperes.

CURRENT LEVEL—

Fault: < 2.0 mA.

Calibration Mode: 3.4 mA (non-adjustable).

LOAD RESISTANCE—Option A: 125 ohms

maximum.

Option B: 500 ohms maximum.

Refer to “Description” section for additional information regarding impedance option.

TEMPERATURE RANGE—

Operating: -40°F to +167°F (-40°C to +75°C).

Storage: -67°F to +185°F (-55°C to +85°C).

HUMIDITY RANGE—

0 to 99% RH, non-condensing.

RFI/EMI IMMUNITY—

Less than ± 0.5 mA signal output variation with a 5 watt, 157 Mhz or 451 Mhz walkie-talkie keyed at distances greater than 1 foot from Model 505 with junction box cover installed.

DIMENSIONS—

See Figure 4.

CERTIFICATION—

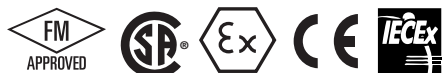

For complete approval details, refer to the appropriate Appendix:

Appendix A – FM
 Appendix B – CSA
 Appendix C – ATEX/CE
 Appendix D – IECEx.

CATALYTIC SENSOR

TEMPERATURE RANGE—

Operating: -67°F to +257°F (-55°C to +125°C).
 Performance: -40°F to +167°F (-40°C to +75°C).

HUMIDITY RANGE—

0 to 99% RH, non-condensing.

RESPONSE TIME—

50% full scale in 3.8 seconds with 100% LFL applied, 5% by volume.
 90% full scale in 8.4 seconds with 100% LFL applied, 5% by volume.
 60% full scale in < 10 seconds with 100% methane by volume in air (CSA flooding test).

RECOVERY TIME—

Less than 30 seconds after exposure to pure methane.

ACCURACY—

±3% LFL from 0 to 50% LFL,
 ±5% LFL from 51% to 100% LFL.

REPEATABILITY—

±1% LFL.

LONG TERM STABILITY—

Zero: < 1% LFL per month.
 Span: < 1% LFL per month in clean air.

TEMPERATURE STABILITY—

< ±5% LFL: -13°F to +167°F (-25°C to +75°C).
 < ±10% LFL: -40°F to -13°F (-40°C to -25°C).

TYPICAL SENSOR LIFE—

3 to 5 years, when environment is free of substances and conditions known to be detrimental to catalytic sensing elements.

STORAGE LIFE—

Indefinite if sensor is stored within the specified temperature range and remains in unopened original packaging.

CALIBRATION CYCLE—

30 days after initial calibration and every 90 days thereafter, or as required by the application and environment.

DIMENSIONS—

See Figure 5.

CERTIFICATION—

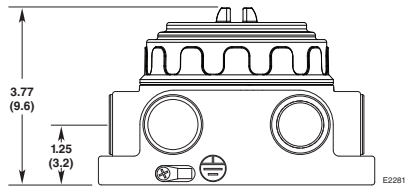
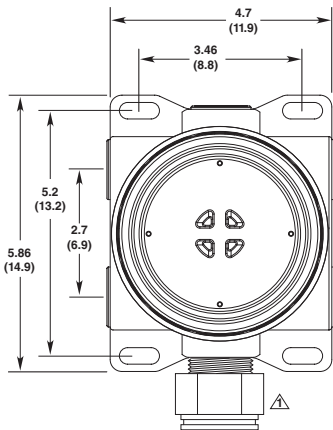

SEE FIGURE 5 FOR SENSOR DIMENSIONS

Figure 4—Dimensions of Transmitter Junction Box in Inches (Centimeters) Multiport Model

For complete approval details, refer to the appropriate Appendix:

- Appendix A – FM
- Appendix B – CSA
- Appendix C – ATEX/CE
- Appendix D – IECEx.

NOTE

Ensure sensor hazardous (classified) location rating is applicable for the intended use.

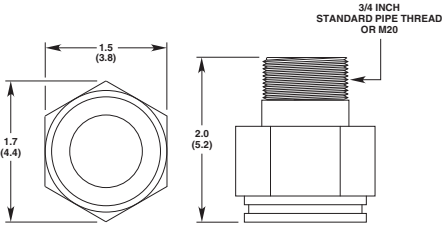

Figure 5—Dimensions of Sensor in Inches (Centimeters)

SECTION II INSTALLATION AND STARTUP

INSTALLATION

CAUTION

Always store and transport the sensor in the original factory packaging to ensure proper protection against contamination.

SENSOR LOCATION

Proper sensor positioning is essential to ensure maximum gas detection capability. Optimum sensor placement and density varies depending upon the conditions at the job site. The system designer and installer must examine the specific area to be protected and identify the most likely leak sources and gas accumulation areas to determine the best sensor locations.

The following factors should be considered for every installation:

1. What kind of gas is to be detected? If it is lighter than air (Acetylene, Hydrogen, Methane, etc.), place the sensor above the potential gas leak. Place it close to the floor for gases that are heavier than air (Benzene, Butane, Butylene, Propane, Hexane, Pentane, etc.) or for vapors resulting from flammable liquid spills. Careful analysis of both the vapor hazard and the application is required — first to determine the feasibility of detection and then to ensure that proper sensor locations are selected.
2. How rapidly will the gas diffuse into the air? Locate the sensor as close as practical to the anticipated source of a gas leak.
3. Ventilation characteristics of the immediate area must also be considered. Air movement can cause the gas to accumulate more heavily in one area than another. Smoke generator tests are useful in identifying typical air current patterns as well as “dead” air spots for both indoor and outdoor applications. The sensors should be placed where the most concentrated accumulation of gas is anticipated.
4. The sensor should be located in an area where it is safe from potential sources of contamination that could poison the sensing element.
5. The sensor should be pointed down to prevent the buildup of contaminants on the gas inlet.
6. The sensor must be accessible for testing and calibration.
7. Exposure to excessive heat or vibration can result in premature failure of electronic devices and should be avoided if possible. Shielding the transmitter from intense sunlight will reduce solar heating and enhance the service life of the unit.

IMPORTANT

All diffusion-based gas sensors including the catalytic gas sensor used with the Model 505 must contact the target gas in order to provide an accurate gas measurement and response. This must always be remembered when selecting locations for gas sensor installation.

WIRING REQUIREMENTS

Wire Size and Type

The transmitter is typically connected to the controller/power source using a three conductor shielded cable. Shielded cable is highly recommended to protect against interference caused by EMI and RFI. Cable shields should be connected to earth ground at the transmitter end only for maximum noise immunity. Shield termination to ground at the controller end only is also acceptable, but may offer reduced noise immunity.

The maximum allowable distance between the Model 505 and the output signal receiver (controller) is determined by the wire size used. For the Model 505 with signal loop impedance option "A," the maximum loop resistance is 125 ohms. For the Model 505 with signal loop impedance option "B," the maximum loop resistance is 500 ohms. Calculate the total linear distance and overall resistance of the signal cable. Do not exceed the maximum loop resistance for the Model 505 version being installed.

Power cable size must be adequate to ensure that no less than the minimum operating voltage is delivered to the transmitter under all operating conditions. Minimum operating voltage for the Model 505 with signal loop impedance option "A" is 10 Vdc, for the Model 505 with signal loop impedance option "B" it is 17 Vdc. A linear, filtered and regulated 24 Vdc power supply is recommended. Maximum wire size accepted by the Model 505 wire terminals is 12 AWG (2.5 mm²). It is acceptable to power the Model 505 from a 24 Vdc power source that is remotely located from the output signal receiver.

In applications where the wiring cable is installed in conduit, the conduit should not be used for wiring to other electrical equipment.

Conduit Seals, Drains, and Breathers

The Model 505 Transmitter is designed and approved for use in hazardous areas where explosion-proof equipment certification is required. When installing the Model 505 in such areas, explosion-proof conduit seals should be installed within 18 inches (46 cm) of the transmitter housing. Conduit seals prevent the passage of vapors or flames through the conduit. Seals are recommended even if they are not required by local wiring codes. Conduit systems are never completely air-tight.

As a result, significant amounts of condensation can form within the conduit system. Therefore, it is important to take proper precautions during installation to ensure that moisture will not cause damage to the transmitter or other components of the system.

Conduit raceways should be inclined so that water will flow to low points for drainage and will not collect on conduit seals or inside enclosures. If this is not possible, install conduit drains above the seals to prevent the collection of water, or install a drain loop below the detector with a conduit drain at the lowest point of the loop.

Conduit drains should be installed at water collection points to automatically drain accumulated moisture. Conduit breathers should be installed at upper locations to provide ventilation and allow water vapor to escape. At least one breather should be used with each drain.

When using steel wire armored or mineral-insulated copper-sheathed cable, select an approved gland with a watertight compression stage and an overall gland shroud for outdoor applications. A sealing washer must be fitted between the gland and the conduit/cable entry to ensure IP66 rating.

MODEL 505 WIRING

Wire the Model 505 as shown in Figure 6.

SENSOR SEPARATION

For maximum EMI/RFI protection, it is preferable to mount the sensor directly to the Model 505 junction box. However, in many cases it is desirable to locate the sensor in a remote location where early gas detection is most probable, and install the transmitter in an easy-access location. In this case, a Sensor Termination Box (available from Detector Electronics) should be used to install the sensor separately from the transmitter. See Figure 7.

A continuous, three conductor cable with an overall foil shield must be used with the sensor separation kit. The cable shield drain wire should be cut back and insulated within the sensor junction box and connected to earth ground at the transmitter junction box. Failure to use a shielded cable or properly ground the shield is likely to result in nuisance alarms caused by EMI/RFI problems.

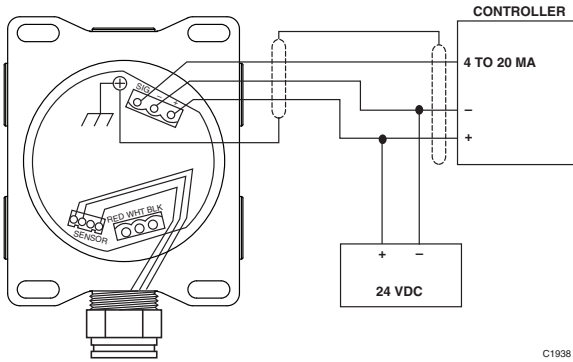

C1938

NOTES:

1. **DO NOT APPLY POWER TO THE TRANSMITTER WITH THE JUNCTION BOX COVER REMOVED UNLESS THE AREA HAS BEEN DE-CLASSIFIED.**
2. **POSITION THE TRANSMITTER WITH THE SENSOR POINTING DOWN.**
3. **THE TRANSMITTER JUNCTION BOX SHOULD BE ELECTRICALLY CONNECTED TO EARTH GROUND.**
4. **ATTACH THE SENSOR TO THE JUNCTION BOX TIGHTLY ENOUGH TO ENSURE AN EXPLOSION-PROOF INSTALLATION, HOWEVER, DO NOT OVERTIGHTEN. LUBRICATE THE THREADS WITH THE CORRECT LUBRICANT TO EASE INSTALLATION AND FUTURE REPLACEMENT. SILICONE BASED LUBRICANTS MUST NEVER BE USED.**
5. **CABLE SHIELDS SHOULD BE CONNECTED TO EARTH GROUND AT ONE END ONLY.**
6. **SHIELDS SHOULD BE STRIPPED BACK FROM CONDUCTORS ONLY WITHIN THE JUNCTION BOX ENCLOSURE.**

Figure 6—Model 505 Transmitter Wiring Without Sensor Separation

The maximum separation distance between the sensor and transmitter is limited by the electrical resistance of the connecting wiring, which is a function of the gauge of the wire being used. Table 1 gives the recommended and absolute maximum sensor separation distances. If the distance is less than the recommended maximum, no adjustment to sensor voltage is required, although measurement of the sensor voltage is recommended to verify proper sensitivity. If the distance is greater than the recommended maximum, refer to the “Sensor Voltage Adjustment” section.

Sensor separation installations with the Model 505 require a special terminal plug for connecting the sensor wiring to the transmitter. This connector (P/N 102883-001) is included with the Sensor Termination Box, and is also available separately for existing installations.

SENSOR VOLTAGE ADJUSTMENT

The combustible gas sensor is designed to operate at 3.3 Vdc. Voltages greater than this will shorten sensor life, while voltages less than this will reduce sensor sensitivity. The sensor supply

voltage potentiometer is adjusted at the factory to deliver 3.3 volts when the sensor is coupled directly to the transmitter housing. However, if the sensor and Model 505 Transmitter are located separately, and the distance exceeds the recommended distance indicated in Table 1, re-adjustment is necessary. To adjust sensor voltage, connect a digital voltmeter across the white and black sensor wires (at the sensor).

Adjust the sensor voltage potentiometer (see Figure 8) to obtain a reading of 3.3 Vdc on the meter. For sensor separation configurations, this is typically a two-person procedure.

Always measure the sensor voltage whenever utilizing a sensor separation kit, and any time a Model 505 transmitter has been replaced. Failure to deliver 3.3 Vdc to the sensor will result in loss of system accuracy.

CAUTION

The voltmeter must be suitable for use in a hazardous location.

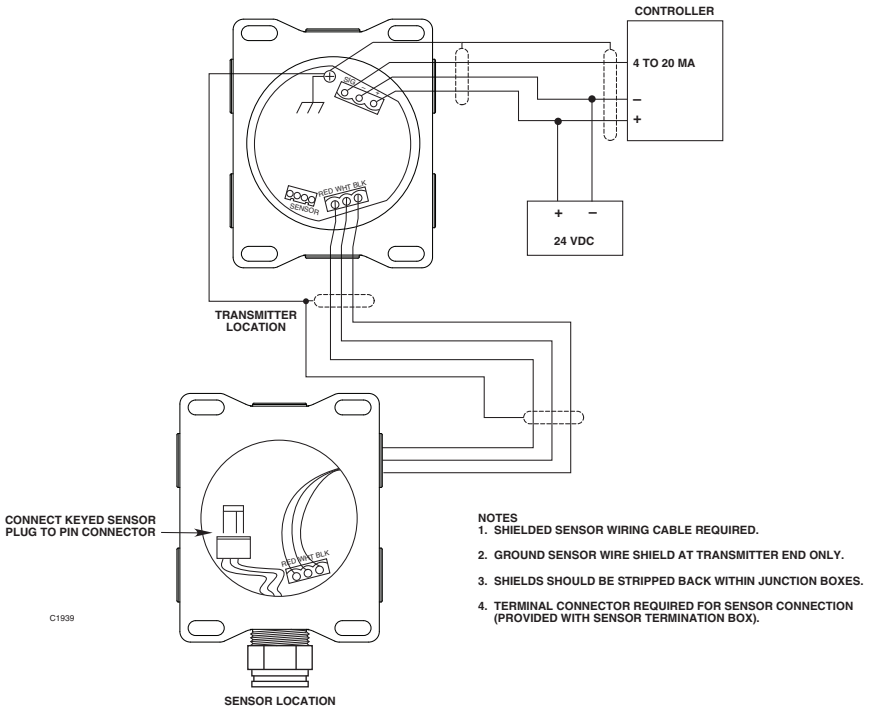

Figure 7—Model 505 Transmitter with Sensor Termination Box

Wire Size (AWG)	Recommended Maximum Transmitter to Sensor Distance*		Maximum Transmitter to Sensor Distance**	
	Feet	Meters	Feet	Meters
20	12	3.6	65	19
18	20	6.1	100	31
16	31	9.4	160	50
14	50	15.2	260	79
12	78	24.0	410	126

* Transmitter voltage adjustment not required.

** Transmitter voltage adjustment is required.

Table 1—Maximum Sensor Separation Distances

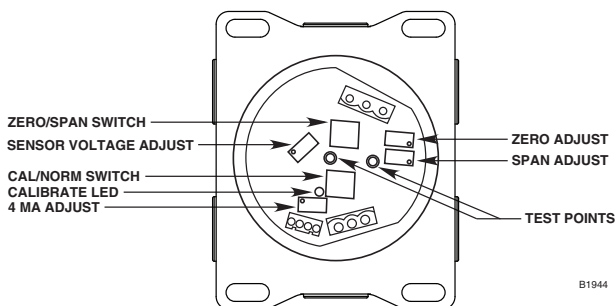

Figure 8—Location of Switches and Potentiometers on Transmitter Circuit Board

REPLACING AN EXISTING K SERIES OR MODEL 500 TRANSMITTER WITH A MODEL 505

1. Remove power from the existing K Series or Model 500 Transmitter, then remove the junction box cover.
2. Remove the transmitter module from the junction box. Do not remove the connector board at this time.
3. Unplug the sensor from the connector board. If the sensor is installed separately from the transmitter junction box, disconnect the three wires from the sensor terminal strip. Note the location of the sensor cable shield drain wire (if used). It will be reconnected in the same manner later.
4. Disconnect the three wires from the power and signal terminal strip. Note the location of the shield drain wire (if used). It will be reconnected in the same manner later.
5. Remove the two screws, then remove the connector board from the junction box.
6. Install the new Model 505 transmitter board in the junction box. The mounting hole pattern of the transmitter board should match the holes in the existing junction box. Use standoffs if necessary to increase the clearance between the transmitter board and the bottom of the junction box. If a ground lug was used, re-install it at the transmitter board mounting hole with the exposed foil to ensure electrical continuity.
7. Remove the plug-in connector for the power and signal wiring from Model 505 transmitter board, and connect the existing power supply and signal wires at the proper locations on the connector. The proper locations are identified on the Model 505 transmitter board by "+ (plus), - (minus) and sig (signal)" markings.
8. Insert the plug-in connector into the power and signal wire receptacle on the Model 505 transmitter board. Reconnect the power and signal cable shield drain wire (if used) as previously installed. Route any excess power and signal wiring inside the junction box around the perimeter of the Model 505 transmitter board to allow easy access to the switches and potentiometers.
9. Connect the sensor plug onto the male sensor terminal. If the sensor is installed separately from the transmitter junction box, connect the three sensor wires to the sensor wiring plug-in connector. The proper sensor wire locations are identified on the Model 505 transmitter board by "red, wht and blk" markings. Note the location of the sensor cable shield drain wire (if used) and ensure that it is re-connected as in the original wiring configuration.
10. Route the sensor wires inside the junction box around the perimeter of the transmitter board to allow easy access to the switches and potentiometers.

11. Apply power to the transmitter and perform "Startup Procedure," "Sensor Voltage Adjustment" and "Calibration" as described in this manual.
12. Replace the junction box cover when complete.

STARTUP PROCEDURE

1. Output loads that are normally actuated by the system should be secured (remove power from all output devices) to prevent undesired activation of these devices.

NOTE

Prior to calibration, it is possible for the transmitter to generate a spurious signal output up to 20 mA when power is first applied.

2. Double check all internal and external wiring for proper connections. Check sensor operating voltage if sensor separation is utilized.
3. If a controller is used, set the alarm setpoints for the desired levels. (Refer to the controller instruction manual.)
4. Apply power to the Model 505. Allow the transmitter/sensor to stabilize for two hours minimum before calibration for maximum accuracy and repeatability.

NOTE

When power is applied to the Model 505, it enters a 15 second time delay before beginning normal operation. This power-up time delay allows time for the sensor to stabilize before the signal output is generated.

5. Calibrate the Model 505 Transmitter using the Calibration Procedure described below.

CAUTION

Calibration of the Model 505 Transmitter requires removal of the junction box cover with power applied. Therefore, the hazardous area must be de-classified.

6. After calibration is completed, restore the system output loads to ready condition.

CALIBRATION

The transmitter must be calibrated upon startup and periodically thereafter to ensure proper performance and gas measurement accuracy. Various factors affect the time interval between periodic calibrations (typically 30, 60, or 90 day intervals, depending on the ambient conditions). Since each application is different, the length of time between regularly scheduled calibrations can vary from one installation to the next. In general, the more frequently a system is checked, the greater the reliability. The transmitter must be calibrated:

- Before a new system is initially put into service
- If the sensor is replaced
- If the Model 505 transmitter circuit board is replaced.

For maximum calibration accuracy, allow a new sensor to operate under power for several hours to ensure a stable output before performing calibration. For the highest degree of accuracy, perform a second calibration after 24 hours.

For a new system startup, or when gas hazard conditions change within an existing protected area, calibration should be checked frequently, approximately twice in the first month. The calibration data can then be used to determine the optimum interval between periodic calibrations.

Before performing calibration, the operator should ensure that the sensor opening is pointing down, and examine the sintered metal cover of the sensor to be sure that it is not missing or damaged. If the cover is defective or missing, the sensor must not be operated, since the exposed sensing element can act as an ignition source. A dirty sintered sensor cover can significantly reduce the sensitivity of the sensor. Dust covers, splash guards, or other sensor accessories may be desirable if ambient conditions result in sensor inlet fouling or blockage.

CALIBRATION PROCEDURE

See Table 2. Refer to Figure 8 to locate the potentiometers and test points on the transmitter circuit board. Always calibrate at startup, and after replacing either the sensor or transmitter circuit board.

A digital voltmeter with probes, a screwdriver for adjusting potentiometers, and calibration gas are required for performing a standard calibration.

WARNING

Before removing the junction box cover, verify that no dangerous levels of gas are present.

Step	Switch Position	Operator Action
1	CAL/NORM switch in the CAL position.	<ol style="list-style-type: none">1. LED turns on.2. Connect a digital voltmeter to the transmitter test jacks.3. Set the meter range to 2 Vdc.
2	ZERO/SPAN switch in the ZERO position.	<ol style="list-style-type: none">1. Adjust the ZERO potentiometer to read 0.000 Vdc on the voltmeter. See Note 3 below.
3	ZERO/SPAN switch in the SPAN position.	<ol style="list-style-type: none">1. Adjust the 4 mA potentiometer to read 0.167 Vdc on the voltmeter.2. Apply the 50% LFL calibration gas to the sensor. When the output has stabilized, adjust the SPAN potentiometer for a reading of 0.500 on the voltmeter.
4	ZERO/SPAN switch in the ZERO position.	<ol style="list-style-type: none">1. Sensitivity test. The meter must read greater than 0.015 Vdc. See Note 4 below.2. Remove the calibration gas.3. When the meter reads 0.002 Vdc or less, remove the test probes.
5	CAL/NORM switch in NORM position.	<ol style="list-style-type: none">1. The LED turns off.2. The calibration is complete.3. Replace the junction box cover.

NOTES:

1. When the CAL/NORM switch is in the CAL position, the yellow LED turns on and the 4 to 20 mA output signal goes to 3.4 mA.
2. The voltmeter must be suitable for use in a hazardous location.
3. If the possibility of background gases exists, purge the sensor with clean air prior to the zero adjustment to assure accurate calibration.
4. A typical sensitivity reading with 50% LFL gas applied to the sensor is 35 to 50 millivolts for a new sensor. Sensor replacement is recommended when the sensitivity reading is less than 15 millivolts.
5. If a dust cover or splash shield is used, inspect it to be sure that it is not dirty or plugged. A plugged dust cover can restrict the flow of gas to the sensing element, seriously reducing its effectiveness. For optimum performance, sensor covers/filters should be replaced frequently to ensure that they are not degraded or plugged.

Table 2—Calibration Procedure

It is important to maintain a log book for all system calibrations performed, and to record the zero, span, adjustment, and sensor sensitivity data before and after each calibration is performed.

NOTE

If sensor response to 50% LFL methane is less than 15 millivolts, the sensor should be replaced. Refer to Table 2, "Calibration Procedure" for information regarding calibration and sensor sensitivity.

CALIBRATION USING K-FACTORS

The Span (gain) control adjusts the Model 505 signal output (% LFL reading) to match the LFL percentage of the applied calibration gas. The span setting will vary for different combustible gases. Therefore, calibration should always be performed using the same gas as the one expected to be detected. If the gas or vapor to be detected is not available from Det-Tronics in a compressed calibration gas kit, then a "K-factor" must be used to ensure proper sensitivity to the gas hazard.

Refer to Det-Tronics Technical Note 76-1017 for information and guidance in using K-factors.

To calibrate the Model 505 in an application that requires the use of K-factors:

1. Determine the calibration span output level using the formula:

$$C \times K = S$$

C — Concentration of calibration gas in % LFL

K — K-factor from Table 1 in 76-1017

S — span output level

2. Multiply the span output level (S) by 0.0067, then add 0.17 to obtain the new calibration span output level (S1).

$$(S \times 0.0067) + 0.17 = S1$$

3. Calibrate the Model 505 using the new calibration span output level (S1) when adjusting the span potentiometer.

Example:

Calibration gas being used — 50% LFL Methane
Gas to be detected — Acetone

1. Use formula: $C \times K = S$
C = Concentration of calibration gas in % LFL = 50 K = K-factor from Table 1 in 76-1017 = 1.44

$$50 \times 1.44 = 72$$

$$S = 72$$

2. Use formula: $(S \times 0.0067) + 0.17 = S1$
S = span output level (determined in step 1) = 72

$$(72 \times 0.0067) + 0.17 = S1$$

$$(72 \times 0.0067) = 0.48$$

$$0.48 + 0.17 = 0.65$$

$$S1 = 0.65$$

3. Calibrate the Model 505 for a reading of 0.65 Vdc on the voltmeter with a calibration mixture of 50% LFL methane applied to the sensor.

NOTE

This procedure applies only to the Model 505 Transmitter. Other Det-Tronics transmitters use the standard K-factor formula.

SECTION III SYSTEM MAINTENANCE

TROUBLESHOOTING

Table 3 is intended to serve as an aid in locating the cause of a malfunction.

The transmitter is not designed to be repaired in the field. If a problem should develop, first check for proper wiring, calibration and sensor sensitivity. If it is determined that the problem is caused by an electrical malfunction in the transmitter, the unit must be returned to the factory for repair.

NOTE

Record all faults on the Fault Record Sheet supplied at the back of this manual.

ROUTINE MAINTENANCE

The Model 505 Transmitter requires no routine maintenance, except for periodic checks to ensure proper calibration. The frequency of these checks is determined by the requirements of the particular installation. Calibration gas kits are required for these checks.

CHECKOUT IN NORMAL MODE

The entire gas detection system should be checked periodically to ensure that the presence of gas at the sensor will result in the proper system response.

SENSOR INSPECTION

Since a dirty or plugged sensor filter can adversely affect the response time of the sensor by restricting the flow of gas to the sensing element, it should be inspected on a regular basis. If a dust cover or splash shield is used, it should also be checked.

SENSOR SENSITIVITY

If sensor response to 50% LFL methane is less than 15 millivolts, the sensor should be replaced. Refer to Table 2, "Calibration Procedure" for information regarding calibration and sensor sensitivity.

SENSOR REPLACEMENT

De-classify the area prior to replacing the sensor and secure any output devices connected to the system to prevent unwanted actuation of this equipment. To replace the sensor:

1. Verify that no hazardous levels of combustible gas are present at the sensor, then remove the cover from the junction box.
2. Unplug the sensor from the circuit board and unscrew it from the junction box.
3. Coat the threads of the new sensor with silicone free grease, then screw the sensor into the junction box and plug it into the circuit board.
4. Allow the sensor output to stabilize under power (about two hours minimum for best results), then perform the calibration procedure described in the "Calibration" section of this manual.
5. For the highest degree of calibration accuracy, perform a second calibration after 24 hours.

A Recommended Test Form is supplied at the back of this manual for recording maintenance performed on the system.

REPLACEMENT PARTS

An adequate supply of spare sensors should be kept on hand for field replacement. For maximum protection against contamination and deterioration, they should not be removed from the original protective packaging until the time of installation.

Always calibrate after replacing either the sensor or the transmitter circuit board.

DEVICE REPAIR AND RETURN

Prior to returning devices, contact the nearest local Detector Electronics office so that a Return Material Identification (RMI) number can be assigned.

A written statement describing the malfunction must accompany the returned device or component to assist and expedite finding the root cause of the failure.

Pack the unit properly. Always use sufficient packing material. Where applicable, use an antistatic bag as protection from electrostatic discharge.

NOTE

Det-Tronics reserves the right to apply a service charge for repairing returned product damaged as a result of improper packaging.

SYMPTOM	POSSIBLE CAUSE
Controller display shows full scale reading	Over 100% LFL gas at sensor. Take appropriate safety measures. Transmitter not calibrated. Defective sensor. Power (+) shorted to signal.
No output from transmitter	Power supply failure. Power or signal wiring problem.
Negative % LFL display at controller	No power to transmitter. Transmitter not calibrated. Sensor not connected. Defective sensor. SIG wire problem. CAL/NORM switch in CAL position.
Signal level at controller different than at transmitter	Loose wiring connection. Total signal wiring loop impedance too high. Induced EMI/RFI interference from nearby EMI fields (motors, switches, etc.). Improper earth ground connection of signal wire shield.

Table 3—Troubleshooting Guide

Return all equipment transportation prepaid to the factory in Minneapolis.

ORDERING INFORMATION

When ordering, please specify:

Model 505 Catalytic Combustible Gas Transmitter

Refer to the 505 Model Matrix for details

NOTE

It is highly recommended that a complete spare be kept on hand for field replacement to ensure continuous protection.

505 MODEL MATRIX

MODEL	DESCRIPTION	
505	Catalytic Combustible Gas Transmitter	
	TYPE	ENCLOSURE MATERIAL
	A	Aluminum
	S	Stainless Steel
	TYPE	CONDUIT ENTRIES AND ORIENTATION
	2	2-ports, ST-straight-through config (180 degree orientation)
	3	2-ports, L-configuration (90 degree orientation)
	4	3-ports, T-configuration
	5	5-ports
	TYPE	THREAD TYPE
	A	3/4" NPT
	C	Metric M20/M25
	TYPE	OUTPUT
	2	4-20 mA
	TYPE	SIGNAL LOOP IMPEDANCE
	A	0-125 ohms (replaces K series)
	B	100-500 ohms (replaces Model 500)
	TYPE	CLASSIFICATION
	1	Explosion-proof
	TYPE	APPROVALS
	B	INMETRO (Brazil)
	R	VNIIFTRI (Russia)
	W	FM/CSA/ATEX/CE/IECEX

APPENDIX A

FM APPROVAL

THE FOLLOWING ITEMS, FUNCTIONS AND OPTIONS DESCRIBE THE FM APPROVAL.

MODEL 505 SERIES COMBUSTIBLE GAS TRANSMITTER

- Explosion-proof for Class I, Division 1, Groups B, C, & D Hazardous (Classified) Locations per FM 3615.
- Dust-ignitionproof for Class II, Division 1, Groups E, F, & G, Class III Hazardous (Classified) Locations per FM 3615. (For use with Sensor Termination Box.)
- Enclosure rating NEMA/Type 4X per ANSI/NEMA 250. (For use with Sensor Termination Box.)
- Operating temperature limits are -40°C to $+75^{\circ}\text{C}$ (-40°F to $+167^{\circ}\text{F}$).
- Storage Temperature Limits are -55°C to $+85^{\circ}\text{C}$ (-67°F to $+185^{\circ}\text{F}$).
- Explosion-proof ambient temperature limits are -55°C to $+125^{\circ}\text{C}$ (-67°F to $+257^{\circ}\text{F}$).
- Relative humidity range is 5 to 95% RH.
- Performance verified for 0 to 100% LFL methane-in-air atmospheres per FM 6320. Accuracy: $\pm 3\%$ LFL from 0 to 50% LFL, $\pm 5\%$ LFL from 51% to 100% LFL.
- For use with 226365-118 through 226365-125 Sensor Termination Boxes.
- For use with Model CGS Series Combustible Gas Sensor.

NOTE

*The high temperature characteristic has **not** been FM performance verified above 75°C .*

NOTE

*Detector Electronics combustible gas detection K factors are **not** FM verified.*

NOTE

Metric straight thread types are for use in non-North American applications.

Calibration

- Calibration of the above listed sensors has been FM verified using the Det-Tronics 225130-001 (50% LFL methane) Calibration Kit.

APPENDIX B

CSA APPROVAL

THE FOLLOWING ITEMS, FUNCTIONS AND OPTIONS DESCRIBE THE CSA APPROVAL.

MODEL 505 SERIES COMBUSTIBLE GAS TRANSMITTER

- Explosion-proof for Class I, Division 1, Groups B, C, & D Hazardous Locations per CSA C22.2 #30.
- Dust/ignition-proof for Class II, Division 1, Groups E, F, & G, Class III Hazardous Locations per CSA C22.2 #25. (For use with Sensor Termination Box.)
- Enclosure Rating NEMA/Type 4X per CSA C22.2 #94. (For use with Sensor Termination Box.)
- Operating temperature limits are -40°C to $+75^{\circ}\text{C}$ (-40°F to $+167^{\circ}\text{F}$).
- Storage temperature limits are -55°C to $+85^{\circ}\text{C}$ (-67°F to $+185^{\circ}\text{F}$).
- Explosion-proof ambient temperature limits are -55°C to $+125^{\circ}\text{C}$ (-67°F to $+257^{\circ}\text{F}$).
- Relative humidity range is 5 to 95% RH.
- Performance verified for 0 to 100% LFL methane-in-air atmospheres per CSA C22.2 #152. Accuracy: $\pm 3\%$ LFL from 0 to 50% LFL, $\pm 5\%$ LFL from 51% to 100% LFL.
- For use with 226365-118 through 226365-125 Sensor Termination Boxes.
- For use with Model CGS Series Combustible Gas Sensor.

NOTE

The high temperature characteristic has not been CSA verified above 75°C .

NOTE

Detector Electronics combustible gas detection K factors are not CSA verified.

NOTE

Metric straight thread types are for use in non-North American applications.

Calibration

- Calibration of the above listed sensors has been CSA verified using the Det-Tronics 225130-001 (50% LFL methane) Calibration Kit.

APPENDIX C

ATEX / CE APPROVAL

ATEX CERTIFICATION

MODEL 505 SERIES COMBUSTIBLE GAS TRANSMITTER

INPUT VOLTAGE—

18 to 30 Vdc

POWER CONSUMPTION—

4.0 watts maximum

CE 0539 Ex II 2 G

Ex db IIC T5-T6 Gb EN60079-29-1

DEMKO 02 ATEX 131329X

T6 (Tamb = -55°C to +60°C)

T5 (Tamb = -55°C to +75°C)

IP66.

EN Standards: EN 50270: 2006
EN 60079-0: 2012+A11: 2012
EN 60079-1 2007
EN 60529: 1991+A1: 2000
EN 60079-29-1: 2007

Combustible gas performance certified per EN 60079-29-1: 2007 when used with Model CGS or any 4-20 mA stand alone combustible gas detector.

Read and understand instruction manual before operating.

To obviate the risk of hotspots and capacitor energy storage, the enclosure must not be opened, even when isolated, when an explosive gas atmosphere is present.

All cable entry devices and blanking elements shall be certified in type of explosion protection flameproof enclosure "d", suitable for the conditions of use and correctly installed. Unused apertures shall be closed with suitable certified blanking elements.

For ambient temperatures above -10°C and above +60°C, use field wiring suitable for both minimum and maximum ambient temperatures.

Special Conditions for Safe Use of Model 505 Transmitter:

The transmitter has an ambient temperature rating for performance of -40°C to +75°C.

CATALYTIC COMBUSTIBLE GAS SENSOR (CGS)

CE 0539 Ex II 2 G

Ex db IIC T3, T5 Gb EN60079-29-1

DEMKO 02 ATEX 131323X

T5 (Tamb = -40°C to +75°C)

T3 (Tamb = -55°C to +125°C).

EN Standards: EN IEC 60079-0:2018
EN 60079-1:2014
EN 60079-29-1:2016

Special Conditions for Safe Use of CGS:

The CGS Combustible Gas Sensor is certified for use in following ambient temperatures:

- ambient temperature range -40°C to $+75^{\circ}\text{C}$.

Coding: **Ex db IIC T5 Gb**

- ambient temperature range -55°C to $+125^{\circ}\text{C}$.

Coding: **Ex db IIC T3 Gb**

The actual temperature range is marked on the sensor.

The performance ambient temperature rating is limited to -40°C to $+75^{\circ}\text{C}$.

The CGS Combustible Gas Sensor can withstand repeated exposures to 125°C for periods up to 12 hours. It is recommended that the sensor be replaced after maximum 500 hours of exposed to the 125°C temperature condition.

The CGS Combustible Gas Sensor must only be mounted into the enclosures of the Universal Display Unit UD10, AV10, UD30, AV30, the Digital Communication Unit EQ22xxDCUEx Series or the Sensor Termination Box Model STB Series.

The CGS Combustible Gas Sensor must be used in conjunction with the before mentioned ATEX certified Detector Electronics Corp. combustible gas detector control units for compliance with EN 60079-29-1 standards.

The actual enclosure must provide a maximum measured reference pressure of 15 bar measured according to EN 60079-1: 2014, §15.

The CGS Combustible Gas Sensor is to be installed in places where there is a low risk of mechanical damage. Flameproof joints are not user serviceable; contact Det-Tronics Service.

CE MARK

DIRECTIVE CONFORMITY

Low Voltage – 2006/95/EC, 2014/35/EU.

Electromagnetic compatibility – 2004/108/EC, 2014/30/EU

ATEX – 94/9/EC, 2014/34/EU.

The Model 505 Series Combustible Gas Transmitter was tested and found to be compliant with EN50270 when wired in conduit or with shielded cable. All screen drains shall be terminated to the chassis.

APPENDIX D

IECEX APPROVAL

MODEL 505 SERIES COMBUSTIBLE GAS TRANSMITTER

IECEX ULD 10.0008X
Ex db IIC T5-T6 Gb
T6 (Tamb = -55°C to +60°C)
T5 (Tamb = -55°C to +75°C)
IP66.

IEC Standards: IEC 60079-0: 2011
IEC 60079-1: 2007
IEC 60529, 2.1.ed.+Corr. 1:2003+2:2007

Read and understand instruction manual before operating.

To obviate the risk of hotspots and capacitor energy storage, the enclosure must not be opened, even when isolated, when an explosive gas atmosphere is present.

All cable entry devices and blanking elements shall be certified in type of explosion protection flameproof enclosure "d", suitable for the conditions of use and correctly installed. Unused apertures shall be closed with suitable certified blanking elements.

For ambient temperatures above -10°C and above +60°C, use field wiring suitable for both minimum and maximum ambient temperatures.

CONDITION OF CERTIFICATION:

The Combustible Gas Transmitter, Model 505, has an ambient temperature rating of -55°C to +60 °C for T6 and -55°C to +75°C for T5.

CATALYTIC COMBUSTIBLE GAS SENSOR (CGS)

IECEX UL 21.0018X
Ex db IIC T3, T5 Gb
T5 (Tamb = -40°C to +75°C)
T3 (Tamb = -55°C to +125°C).

IEC Standards: IEC 60079-0, 7th Edition
IEC 60079-1, 7th Edition
IEC 60079-29-1, 2nd Edition

CONDITION OF CERTIFICATION:

The CGS Combustible Gas Sensor is certified for use in following ambient temperatures:

- ambient temperature range -40°C to +75°C.

Coding: **Ex db IIC T5 Gb**

- ambient temperature range -55°C to +125°C.

Coding: **Ex db IIC T3 Gb**

The actual temperature range is marked on the sensor.

The CGS Combustible Gas Sensor can withstand repeated exposures to 125°C for periods up to 12 hours. It is recommended that the sensor be replaced after maximum 500 hours of exposed to the 125°C temperature condition.

The CGS Combustible Gas Sensor must only be mounted into the enclosures of the Universal Display Unit UD10, AV10, UD30, AV30, the Digital Communication Unit EQ22xxDCUEx Series or the Sensor Termination Box Model STB Series.

The CGS Combustible Gas Sensor must be used in conjunction with the before-mentioned IEC/ATEX certified Detector Electronics Corp. combustible gas detector control units for compliance with the IEC/EN 60079-29-1 standard.

The actual enclosure must provide a maximum measured reference pressure of 15 bar measured according to IEC 60079-1: 2007, §15.

The CGS Combustible Gas Sensor is to be installed in places where there is a low risk of mechanical damage.

Flameproof joints are not user serviceable; contact Det-Tronics Service.

RECOMMENDED TEST FORM

Detector Number	Detector Location	Date Installed	Date Checked	Date Calibrated	Remarks

FAULT RECORD SHEET

Date	Time	Date Affected	System Status	Operator	Comments



95-8472



FlexSonic® Acoustic
Leak Detector



X3301 Multispectrum
IR Flame Detector



PointWatch Eclipse® IR
Combustible Gas Detector



FlexVu® Universal Display
with GT3000 Toxic Gas Detector



Eagle Quantum Premier®
Safety System



©2022 Carrier. All Rights Reserved.



Corporate Office
6901 West 110th Street
Minneapolis, MN 55438 USA
www.det-tronics.com

Phone: +1 952.941.5665
Toll-free: +1 800.765.3473
Fax: 952.829.8750
det-tronics@carrier.com